



Cable management
system for cabinets
and equipment

Slotted trunking halogen free

88

raw material

U43X

colour

Grey



88

U43X

Grey

Slotted trunking
halogen free

For cable conduction in electrical and communications cabinets

- Higher safety for the installation assured by the trunking's sturdiness.
- The cover is easy to mount and remove.
- **The cover will stay in place and will not slip in any mounting position.**
- No cutting tips or edges.
- Possibility to cut until the base for better branching.

Raw material

U43X

Trunking, retainers
and cable compactor

Compliant



Technical characteristics

Electrical	Maximum service temperature	Minimum transport and storage temperature	In front of fire
EN 50085-2-3*	EN 50085-2-3*	EN 50085-2-3*	
Insulating material. No earthing required.			Glow-fire test at 960°C. Non flame propagating. Flammability degree UL94: V0. Does not spread fire by dripping. Compliance acc./45545-2: HL3 - R22.

* BS EN 50085-2-3 is the UK implementation of EN 50085-2-3.

Slotted trunking
halogen free

88 U43X
Grey

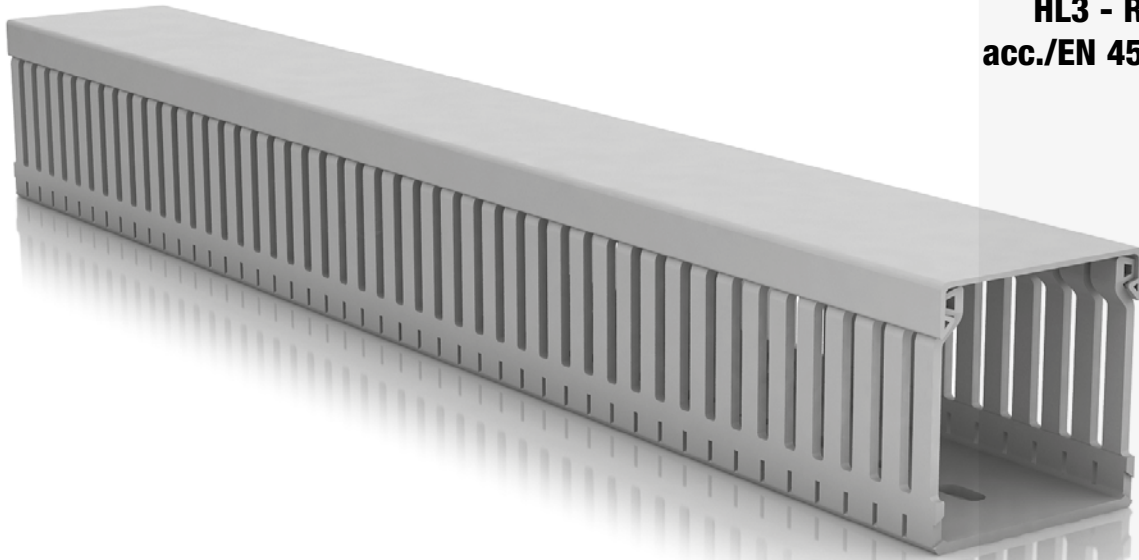

HL3 - R22
acc./EN 45545-2

Length

2 m

Colour

Grey

RAL 7035

Quality marks



Approvals

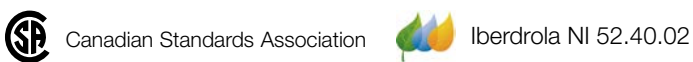

See updated technical
information of each
part number on
www.unex.net

Conformity declaration



88

U43X

Grey

Slotted trunking
halogen free



Rolling stock

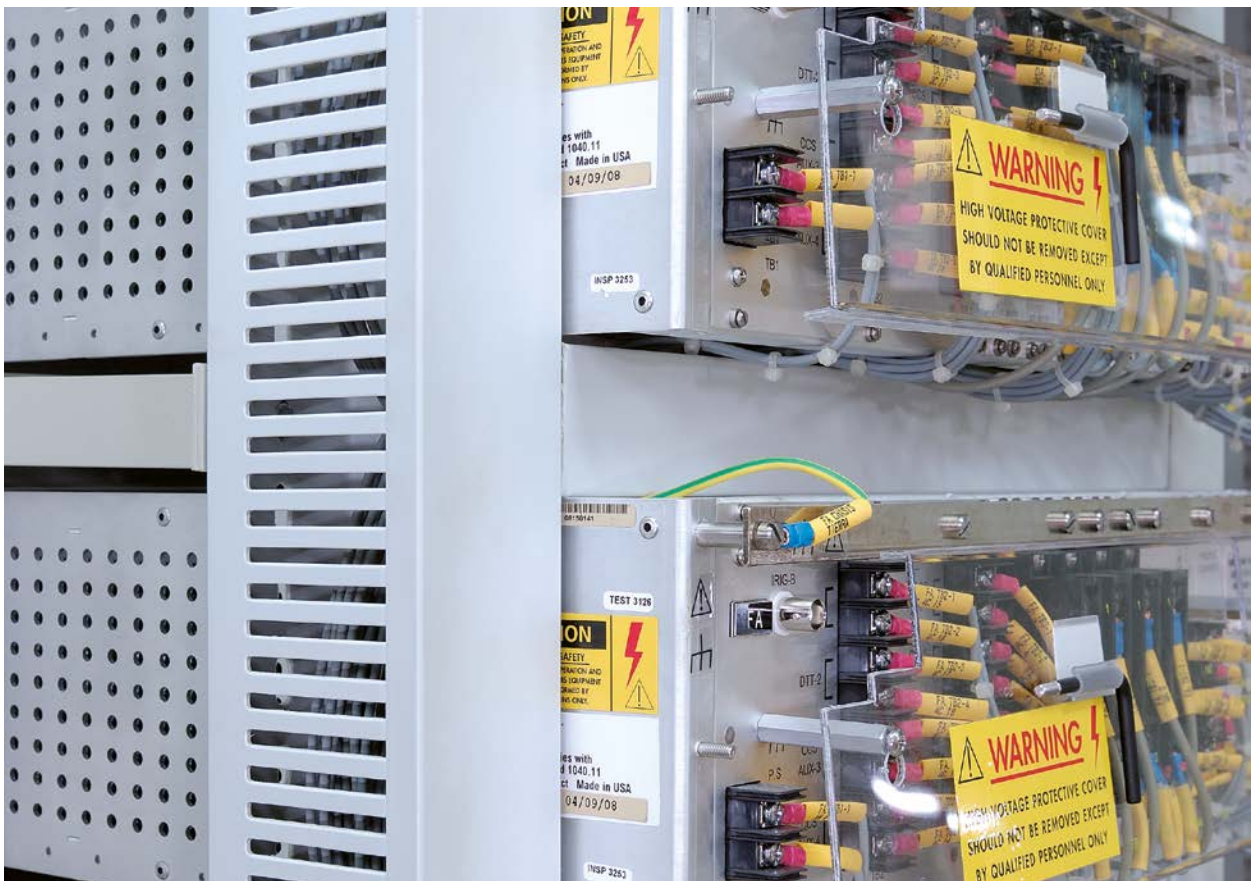

Airport



Railway infrastructure



Airport



Power distribution

88

U43X

Grey

Slotted trunking
halogen free

Easy mounting and maintenance

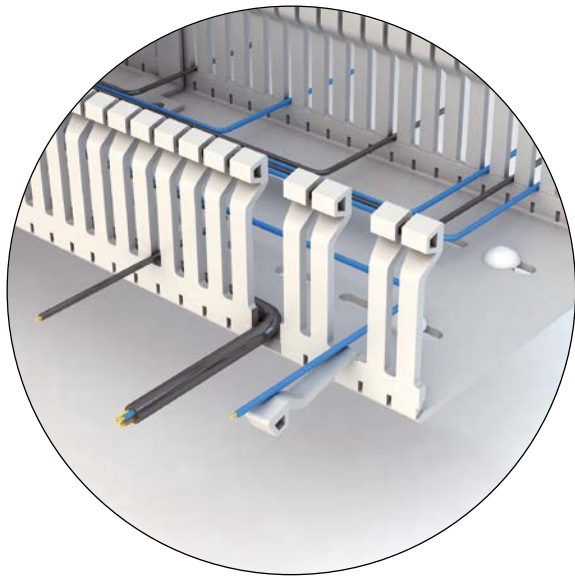

Flexible and resistant fingers,
which do not break accidentally.

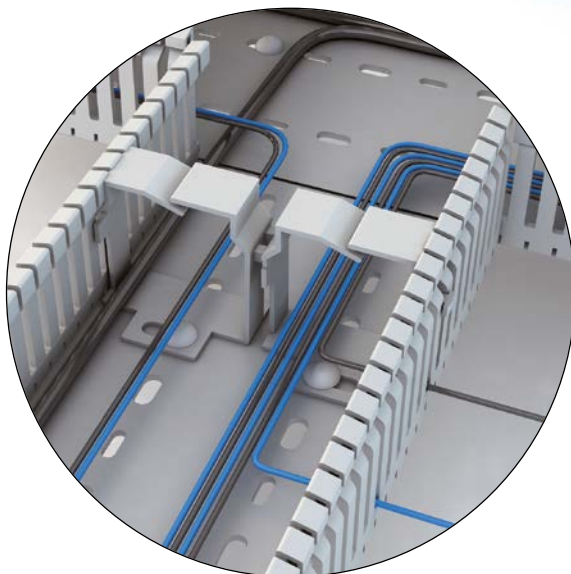
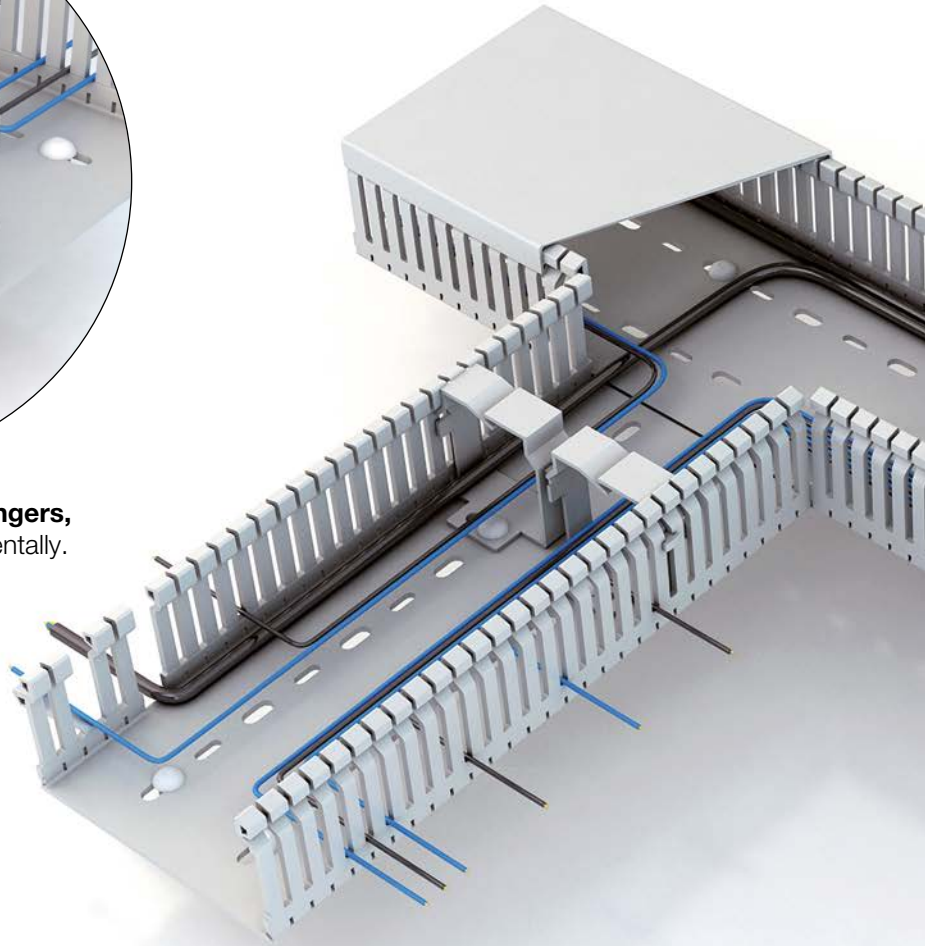

Rigid cable retainer: avoids
deformations and allows circuit
classification. Only 6 part numbers
for 12 trunking sizes.

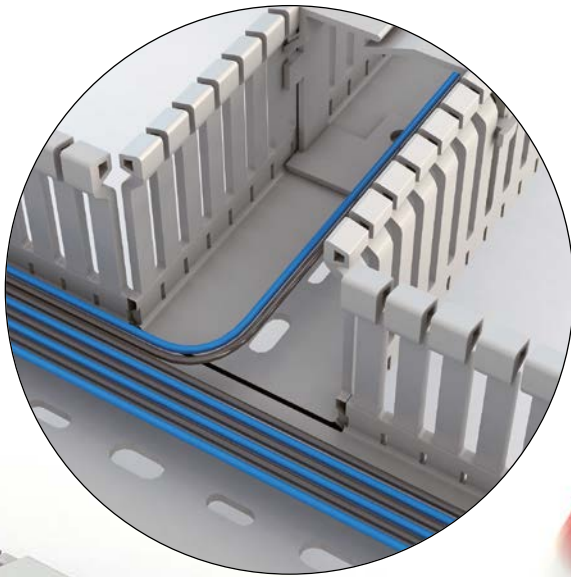

Clean cut of the sidewall to the base.
Does not damage the cables insulation.
Maximum branching room and cross-section.
Quicker mounting and easier cable connections.

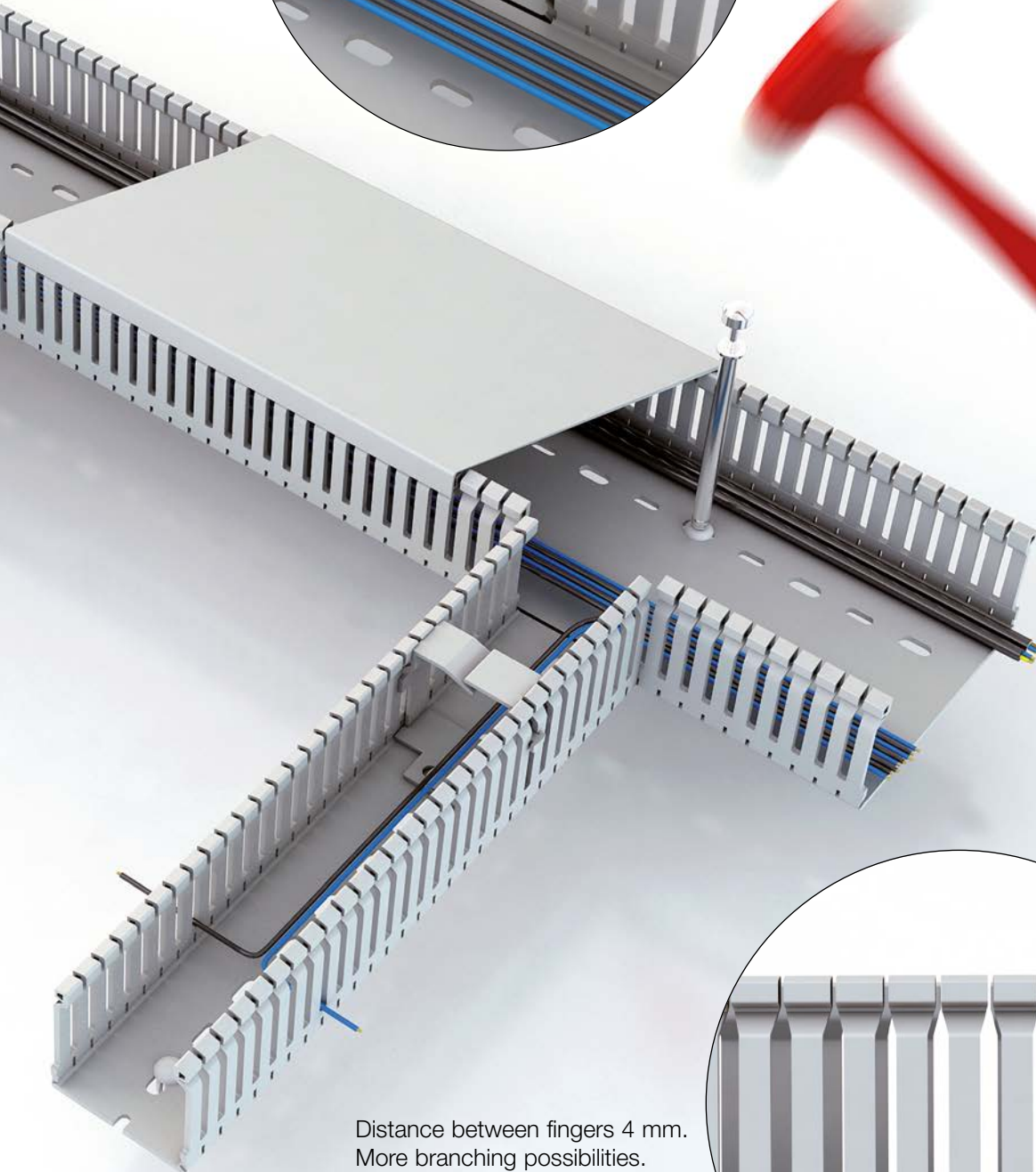

Distance between fingers 4 mm.
More branching possibilities.

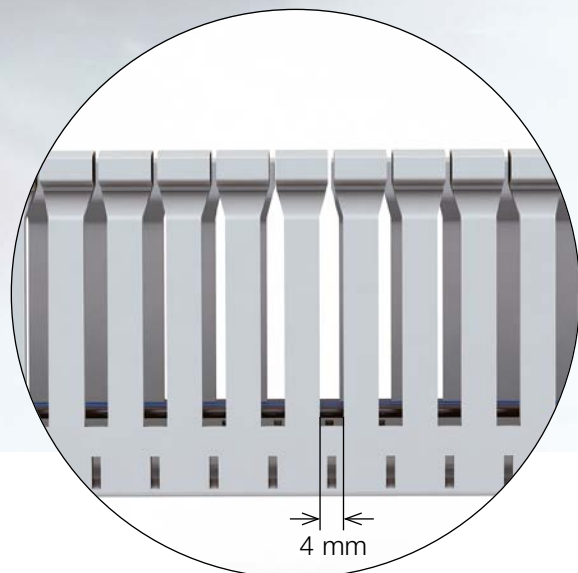

88

U43X

Grey

Slotted trunking
halogen free

A product with added value

Burr-free slotted trunking

Smooth design, without burrs or sharp edges: does not damage the user's hand nor the cables during mounting. The cables insulation is not affected during transportation or in applications submitted to vibrations.



Cover

Easy to mount and remove.

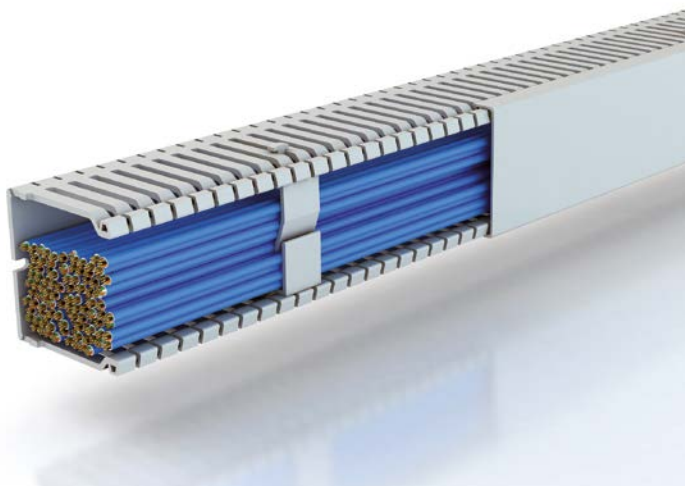

In horizontal position, the fingers do not bend and the cover does not fall.



In vertical position, the cover does not slide.

Solid and sturdy trunking

Due to its solidity and sturdiness, the trunking can be suspended between rails. Few fixings required.



Cable compactor

Only one part number for all trunking sizes: the retainer can be cut according to the trunking's width and can be fixed at any adjustable height.



Possibility to paint

Unex slotted trunkings can be painted with the most common paints.

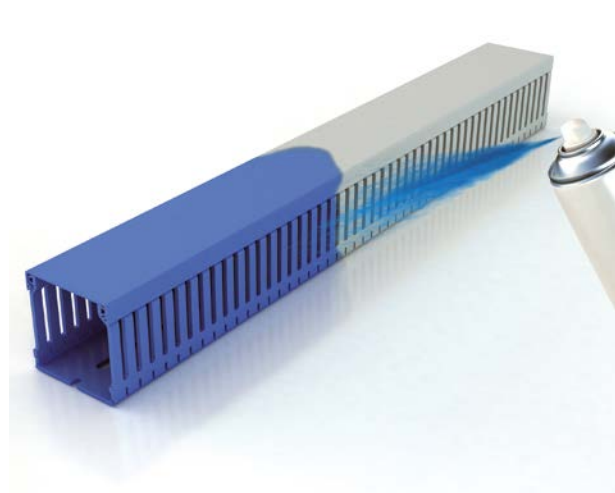



88

U43X

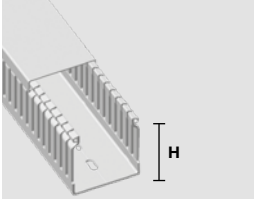

Grey

Slotted trunking
halogen free



Height = 25 mm, 30 mm and 40 mm

		Slotted trunking width (mm)		20	30	40
		 <p>Grey RAL 7035</p>				
 <p>Slotted trunking 2 m</p>	H = 25 mm					
	H = 30 mm				30.30.88	
	H = 40 mm			40.20.88	40.30.88	40.40.88
 <p>Cable compactor</p>				40850		



Height = 60 mm

		Slotted trunking width (mm)		20	30	40
		 <p>Slotted trunking 2 m</p>				
		H = 60 mm			60.30.88	60.40.88
 <p>Cable retainer</p>						40864-4
 <p>Cable compactor</p>					40850	

Height = 80 mm

		Slotted trunking width (mm)		20	30	40
		 <p>Slotted trunking 2 m</p>				
		H = 80 mm			80.30.88	80.40.88
 <p>Cable retainer</p>						40884-4
 <p>Cable compactor</p>					40850	

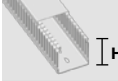
Height = 100 mm

		Slotted trunking width (mm)		20	30	40
		 <p>Slotted trunking 2 m</p>				
		H = 100 mm				100.40.88
 <p>Cable retainer</p>						40894-4
 <p>Cable compactor</p>						40850



	60	80	100	120
	40.60.88			
	40850			

	60	80	100	120
	60.60.88	60.80.88		60.120.88
	40865-4	40864-4 + 40864-4		40865-4 + 40865-4
	40850			40850

	60	80	100	120
	80.60.88	80.80.88	80.100.88	80.120.88
	40885-4	40884-4 + 40884-4	40884-4 + 40885-4	40885-4 + 40885-4
	40850			

	60	80	100	120
	100.60.88	100.80.88	100.100.88	
	40895-4	40894-4 + 40894-4	40894-4 + 40895-4	
	40850			

See next page 

88

U43X

Grey

Slotted trunking
halogen free

Fixing elements in U60X

		Natural	
	Plastic rivet	A = 6 mm Ø B = 6 mm Ø C = 3,0-3,25 mm D = 1-3 mm	1303 (1)
		A = 8 mm Ø B = 11 mm Ø C = 5,1-5,25 mm D = 2-5 mm	1305
		A = 12 mm Ø B = 11 mm Ø C = 6,1-6,5 mm D = 5-9 mm	1309
		A = 21 mm Ø B = 11 mm Ø C = 6,1-6,5 mm D = 10-18 mm	1318
	Riveting tool	Riveting tool: can be used with part no. 1305, 1309 and 1318 L = 225 mm	1300
		Riveting tool: can be used with part no. 1303 L = 120 mm	1301

(1) To fix labels. Do not use to fix trunkings.

Tools

	Cutting tool To cut the main trunking	40902 (1)
--	---	------------------

(1) Cut at 90° for trunking's width ≤ 60 mm Cut at 45° for trunking's width ≤ 40 mm.

Sizes (mm)

	Part. no.	Sizes mm		Fixing holes type	Pack
		Width	Height		
	25.20.88	25	20	1	60
	30.30.88	33	30	1	60
	40.20.88	42	20	1	72
	40.30.88	42	30	1	48
	40.40.88	42	43	1	32
	40.60.88	42	60	1	24
	60.30.88	60	30	1	36
	60.40.88	60	43	1	32
	60.60.88	60	60	1	32
	60.80.88	60	80	2	32
	60.120.88	60	120	2	12
	80.30.88	80	30	1	28
	80.40.88	80	43	1	24
	80.60.88	80	60	1	24
	80.80.88	80	80	2	24
	80.100.88	80	100	2	12
	80.120.88	80	120	2	12
	100.40.88	100	43	1	16
	100.60.88	100	60	1	16
	100.80.88	100	80	2	16
	100.100.88	100	100	2	8

Fixing holes compatible with EN 50085-2-3*	
Type 1	Type 2

Material: U43X

* BS EN 50085-2-3 is the UK implementation of EN 50085-2-3.

See next page

Useful cross-sections (mm²)



Part no.		Grey RAL 7035		Sizes (mm)	25x20	33x30	40x20	42x30	42x43	42x60
					322	728	586	940	1460	2112
Cables V250 Number of cables (Filling ratio 1.5)*	0.5 mm ²				53	116	96	154	237	346
	0.75 mm ²				35	77	63	102	157	229
Cables H05/07 V-K Number of cables (Filling ratio 1.5)*	1 mm ²				23	50	41	66	102	150
	1.5 mm ²				17	37	30	49	75	110
	2.5 mm ²				12	26	21	34	52	76

Part no.		Grey RAL 7035		Sizes (mm)	60x30	60x43	60x60	60x80	60x120
					1387	2137	3092	4225	6380
Cables H05/07 V-K Number of cables (Filling ratio 1.5)*	1 mm ²				98	150	219	299	450
	1.5 mm ²				72	111	161	220	331
	2.5 mm ²				50	77	112	153	230
	4 mm ²				40	61	89	122	184
	6 mm ²				23	35	51	70	106

Part no.		Grey RAL 7035		Sizes (mm)	80x30	80x43	80x60	80x80	80x100	80x120
					1865	2874	4128	5630	7177	8572
Cables H05/07 V-K Number of cables (Filling ratio 1.5)*	1 mm ²				132	203	291	399	504	606
	1.5 mm ²				97	149	215	293	371	446
	2.5 mm ²				68	104	149	204	258	309
	4 mm ²				54	83	118	162	206	247
	6 mm ²				31	47	68	92	118	142

* Note: For other types of cables, the necessary section results from the application of the following formula: Section = Cable section x no. of cables x 1.5.

See next page

88

U43X

Grey

Slotted trunking
halogen free





Sizes (mm)

100x43

100x60

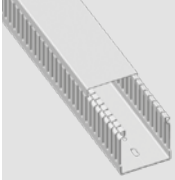
100x80

100x100

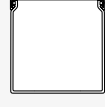
Part no.	Grey RAL 7035	100.40.88	100.60.88	100.80.88	100.100.88
		 3585	 5179	 7110	 9000
Cables H05/07 V-K Number of cables (Filling ratio 1.5)*	1 mm ²	253	366	502	633
	1.5 mm ²	186	271	369	465
	2.5 mm ²	129	188	257	324
	4 mm ²	103	149	204	258
	6 mm ²	59	85	117	148

* Note: For other types of cables, the necessary section results from the application of the following formula:
Section = Cable section x no. of cables x 1.5.

